

TECHNICAL SPECIFICATIONS	
UNIT TYPE:	MONITORED SWITCHED
ORIENTATION:	VERTICAL, 0U FULL
OUTLET QTY & TYPE:	(24)C13/C15, (24)C13/C15/C19
INPUT VOLTAGE:	200-240/346-415VAC
INPUT CURRENT:	30A (24A DERATED) (NAM)/32A(EU)
BREAKER QTY & TYPE:	(6) 20AMP, SINGLE-POLE
INPUT PHASE:	THREE-PHASE (WYE)
RATED POWER:	DUAL- RATED 17.3 kVA (NAM) / 22.1kVA (EU)
INPUT PLUG:	SEE NOTE 7
INPUT POWER CORD:	SEE IDENTIFICATION TABLE
FEATURES	
METERING ACCURACY	+/-1% TO ISO/ IEC 62052-21
METERING ATTRIBUTES	VOLTAGE(V), CURRENT(A), APPARENT POWER(kVA), REAL POWER(kW), POWER FACTOR, ENERGY(kWh)
METERED COMPONENTS	INPUT(PHASE), CIRCUIT BREAKERS
REMOTE OUTLET SWITCHING	YES
ENVIRONMENTAL CONDITIONS	
OPERATING TEMPERATURE	-5 TO 60 C (23 TO 140 F)
STORAGE TEMPERATURE	-20 TO 60 C (-4 TO 140 F)
HUMIDITY (OPERATING/STORAGE)	5-90% RH / 5-95% RH; NON-CONDENSING
MAX OPERATING ELEVATION, ABOVE MSL	3000M(9840FT)
COMPLIANCE	
SAFETY&ENVIRONMENTAL	RoHS COMPLIANT

IDENTIFICATION TABLE	RP 2850	*	*	*	*	**
MODEL IS SHOWN IN DEFAULT CONFIGURATION. FOR OPTIONAL CONFIGURATIONS, USE ITEM IDENTIFIER CODE IN PLACE OF EACH ASTERISK. ORDERABLE BASED ON FORMAT: RP2850****	INPUT PLUG	CHASSIS COLOR	CORD OPTION	ORIENTATION	CB	
DO NOT INCLUDE TRAILING ZEROS IN **** SUFFIX	(DEFAULT) 532P6 (IP44) = 0 532P6 (IP67) = W	(DEFAULT) BLACK = 0 BLUE = B RED = R WHITE = W GREEN = G YELLOW = Y	(DEFAULT) 1.8m [6"] = 0 1m [3.2"] = 1 2m [6.6"] = 2 3m [10"] = 3	(DEFAULT) TOP FEED = 0 BOTTOM FEED = 2		
OPTIONS LISTED ON THIS ROW ARE NON STANDARD. CONTACT SALES FOR ADDITIONAL INFORMATION		ORANGE = A	0.5m [1.6"] = A 1.2m [4"] = G 1.5m [4.9"] = B 1.8m [6"] = F 2.5m [8.2"] = C	(DEFAULT) 5 KAIC CB = 00 10 KAIC CB = 01		

- NOTES :**
- INSTALLATION SHALL COMPLY WITH ALL APPLICABLE NATIONAL, STATE AND LOCAL CODES.
 - PRIMARY DIMENSIONS ARE IN MILLIMETERS. SECONDARY DIMENSIONS ARE IN [INCHES]
 - UNIVERSAL MOUNTING BRACKET IS AN ALTERNATIVE MOUNTING METHOD TO THE TOOLLESS MOUNT FOR 3RD PARTY ENCLOSURES. BRACKET IS PROVIDED WITH THE UNIT.
 - DETAILED INSTALLATION INSTRUCTIONS CAN BE FOUND IN THE QUICK START GUIDE
 - CONNECT EXTERNAL EARTH GROUND TO THE 10-32 SIZE THREADED NUT SEE PRODUCT DOCUMENTATION FOR FURTHER INFORMATION
 - INPUT PLUG CONFIGURATION (SEE IDENTIFICATION TABLE) FOR DUAL-RATED UNITS, NEMA PLUGS ARE NAM RATED ONLY AND CAPTIVE AUS/NZ PLUGS ARE EMEA RATED ONLY

ECN/ECO	REV.	DESCRIPTION	DATE	APPROVED
ECN-2210-0226	E3	REVISE METER ACCURACY AND ATTRIBUTES CONTENT	2022/10/08	LRF
PEC-2208-0039	E2	UPDATED IDENTIFICATION TABLE, ADDED CB MODEL OPTIONS	2022/08/26	Leo Liu
	E1	INITIAL DRAFT REVIEW	2022/04/14	LRF



THIS DRAWING AND SPECIFICATIONS HEREIN ARE THE PROPERTY OF CIS GLOBAL AND SHALL NOT BE COPIED, REPRODUCED OR USED IN WHOLE OR IN PART, AS THE BASIS FOR THE MANUFACTURE OR SALE OF ITEMS WITHOUT WRITTEN PERMISSION FROM CIS GLOBAL. THIS DRAWING IS BASED UPON LATEST AVAILABLE INFORMATION AND IS SUBJECT TO CHANGE WITHOUT NOTICE

TITLE : Advantage Series Metered Switched

PROJECT : RackPower

UNLESS NOTED, DIMENSIONS ARE IN MILLIMETERS & TOLERANCES ARE:
 X ±1 MM X° ±1°
 X.X ±0.5 MM X.X° ±0.5°
 X ±0.20 MM
 Ø X.X ±0.3 MM
 Ø X.XX ±0.10 MM

BRACKETED DIMENSIONS ARE IN INCHES FOR REFERENCE ONLY
 Ⓢ THIRD ANGLE PROJECTION
 INTERPRET PER ASME Y14.5M-1994

PART NO: RP2850WXYZ_DA **REV.:** E3
DRAWN BY: Leo **2022/08/26**
ENGINEER: LJB **2022/10/08**
APPROVED BY: Hanson **2022/10/08**

SCALE : N/A SHEET 1 OF 3 **SIZE:** A3

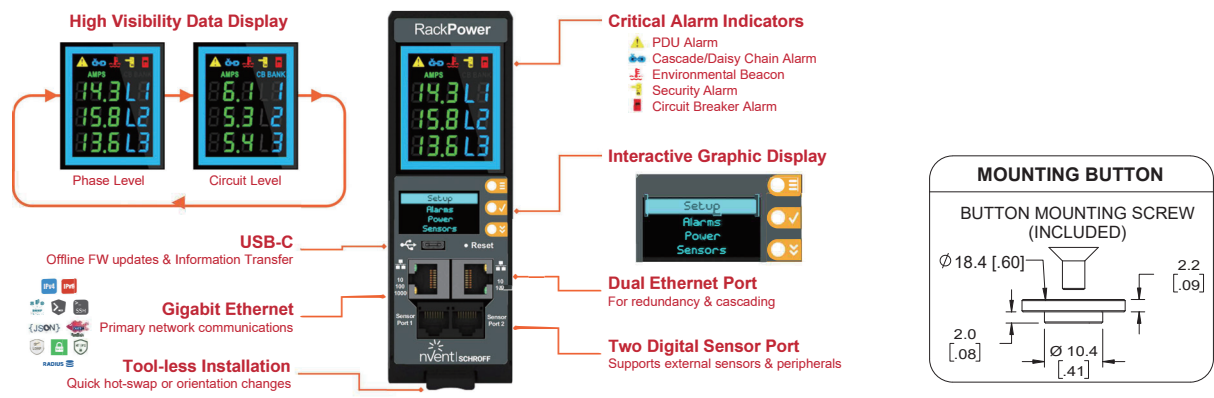
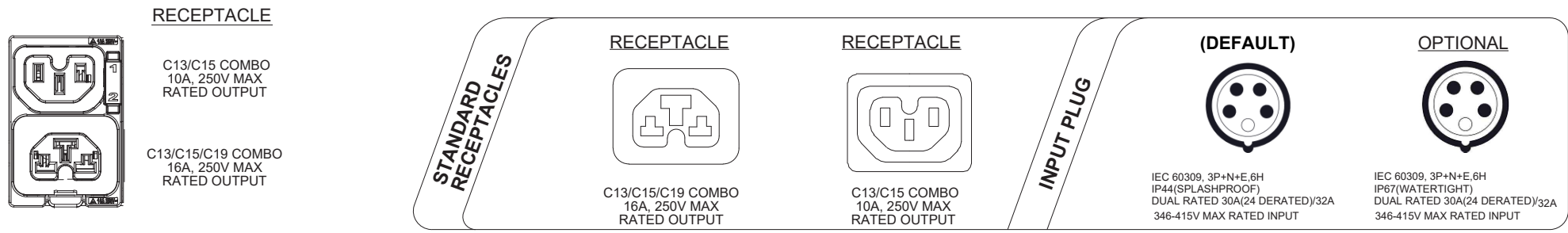
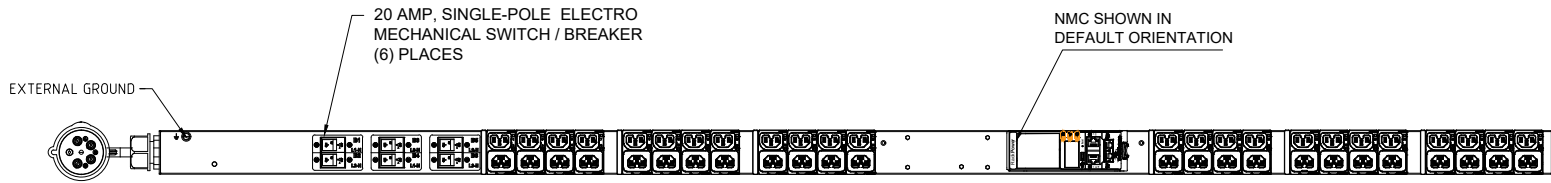

ECN/ECO	REV.	DESCRIPTION	DATE	APPROVED
ECN-2210-0226	E3	REVISE METER ACCURACY AND ATTRIBUTES CONTENT	2022/10/08	LRF
PEC-2208-0039	E2	UPDATED IDENTIFICATION TABLE, ADDED CB MODEL OPTIONS	2022/08/26	Leo Liu
	E1	INITIAL DRAFT REVIEW	2022/04/14	LRF

REVISIONS				
TITLE:	Advantage Series Metered Switched	UNLESS NOTED, DIMENSIONS ARE IN MILLIMETERS & TOLERANCES ARE: X. ±1 MM X° ±1° X.X ±0.5 MM X.X° ±0.5° X.XX ±0.20 MM Ø X.X ±0.3 MM Ø X.XX ±0.10 MM	PART NO: RP2850WXYZ_DA	REV. E3
PROJECT:	RackPower	BRACKETED DIMENSIONS ARE IN INCHES FOR REFERENCE ONLY ⊕ THIRD ANGLE PROJECTION INTERPRET PER ASME Y14.5M-1994	DRAWN BY: Leo ENGINEER: LJB APPROVED BY: Hanson	2022/08/26 2022/10/08 2022/10/08
			SCALE: N/A	SHEET 2 OF 3
				SIZE: A3

nvent | SCHROFF

THIS DRAWING AND SPECIFICATIONS HEREIN ARE THE PROPERTY OF CIS GLOBAL AND SHALL NOT BE COPIED, REPRODUCED OR USED IN WHOLE OR IN PART, AS THE BASIS FOR THE MANUFACTURE OR SALE OF ITEMS WITHOUT WRITTEN PERMISSION FROM CIS GLOBAL. THIS DRAWING IS BASED UPON LATEST AVAILABLE INFORMATION AND IS SUBJECT TO CHANGE WITHOUT NOTICE

NOTES:

- INSTALLATION SHALL COMPLY WITH ALL APPLICABLE NATIONAL, STATE AND LOCAL CODES.
- SEE PRODUCT DOCUMENTATION FOR FURTHER INFORMATION

nvent | SCHROFF RackPower Distribution Unit
Metered Switched

SKU #: RP2850WXYZ
Model #: EP122024-0062-C(NA)/EP122032-0062-C(EU)
INPUT: 200-240/346-415VAC, WYE, 3PHASE, 50/60Hz, 24A(NA), OR 200-240/346-415VAC, WYE, 3PHASE, 50/60Hz, 32A(EU)
OUTPUT: C13/C15 COMBO; 200-240VAC, 10A per outlet
C13/C15/C19 COMBO; 200-240VAC, 16A max per outlet
24A Total(NA) OR 32A Total(EU)

MAC0 Address:XX-XX-XX-XX-XX
MAC1 Address:XX-XX-XX-XX-XX

Made in XXXXX

CE UK CA
vvent Electric plc
1965 Ulms Ave, Suite 700
Minneapolis, MN 55416

SKU#: RP2850WXYZ
Serial Number
XXXXXX

PRODUCT CODE
XXXXXX

THIS DEVICE COMPLIES WITH PART 15 OF THE FCC RULES. OPERATION IS SUBJECT TO THE FOLLOWING TWO CONDITIONS: (1) THIS DEVICE MAY NOT CAUSE HARMFUL INTERFERENCE AND (2) THIS DEVICE MUST ACCEPT ANY INTERFERENCE RECEIVED, INCLUDING INTERFERENCE THAT MAY CAUSE UNDESIRABLE OPERATION. CAN ICES-3(A)/NMB-3(A)

COMPLIANCE LABEL

NOTES:

1. INTERNAL WIRING

- WIRE TYPE: UL AWM 1015, 12 & 18 AWG
- LINE 1/R/X COLOR: Brown
- LINE 2/S/Y COLOR: Black
- LINE 3/T/Z COLOR: White
- NEUTRAL COLOR: Blue
- EARTH GROUND COLOR: Green/Yellow

2. FOR FINISHED GOOD PART NUMBER SEE IDENTIFICATION

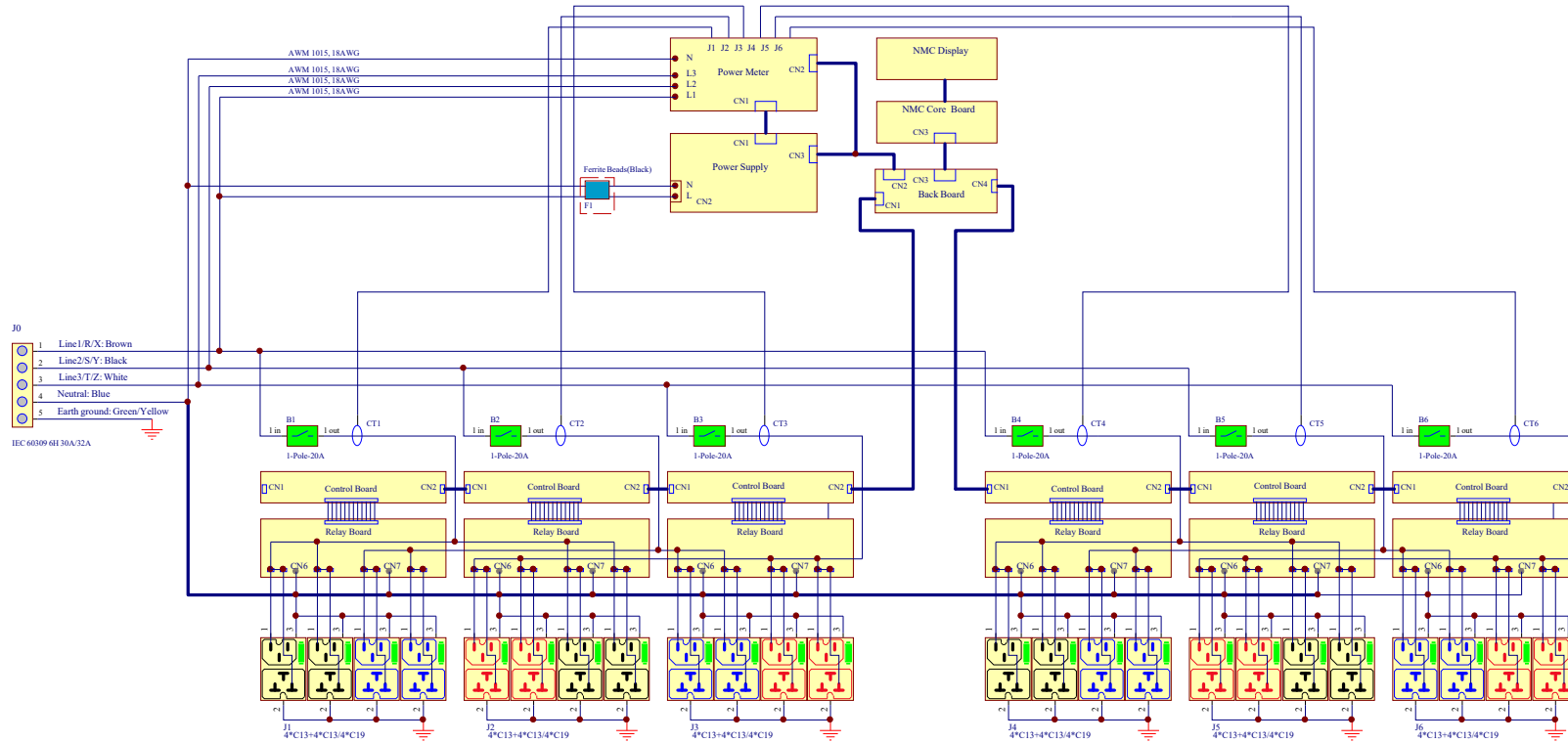

INTERNAL WIRING SCHEMATIC DIAGRAM

NOTES:

- INSTALLATION SHALL COMPLY WITH ALL APPLICABLE NATIONAL, STATE AND LOCAL CODES.
- SEE PRODUCT DOCUMENTATION FOR FURTHER INFORMATION
- THIS DRAWING DEPICTS THE POWER SYSTEM CONNECTIONS AND IS NOT REPRESENTATIVE OF THE PHYSICAL LAYOUT. PLEASE REFER TO MECHANICAL DRAWINGS FOR PHYSICAL LAYOUT.



THIS DRAWING AND SPECIFICATIONS HEREIN ARE THE PROPERTY OF CIS GLOBAL AND SHALL NOT BE COPIED, REPRODUCED OR USED IN WHOLE OR IN PART, AS THE BASIS FOR THE MANUFACTURE OR SALE OF ITEMS WITHOUT WRITTEN PERMISSION FROM CIS GLOBAL. THIS DRAWING IS BASED UPON LATEST AVAILABLE INFORMATION AND IS SUBJECT TO CHANGE WITHOUT NOTICE

ECN-2210-0226	E3	REVISE METER ACCURACY AND ATTRIBUTES CONTENT	2022/10/08	LRF
PEC-2208-0039	E2	UPDATED IDENTIFICATION TABLE, ADDED CB MODEL OPTIONS	2022/08/26	Leo Liu
	E1	INITIAL DRAFT REVIEW	2022/04/14	LRF
ECN/ECO	REV.	DESCRIPTION	DATE	APPROVED

REVISIONS

TITLE: Advantage Series Metered Switched	UNLESS NOTED, DIMENSIONS ARE IN MILLIMETERS & TOLERANCES ARE: X: ±1 MM X*: ±1° X.X ±0.5 MM X.X*: ±0.5° X.XX ±0.20 MM Ø X.X ±0.3 MM Ø X.XX ±0.10 MM	PART NO: RP2850WXYZ_DA	REV. E3
		DRAWN BY: Leo	2022/08/26
PROJECT: RackPower	BRACKETED DIMENSIONS ARE IN INCHES FOR REFERENCE ONLY	ENGINEER: LJB	2022/10/08
	⊕ THRD ANGLE PROJECTION	APPROVED BY: Hanson	2022/10/08
	INTERPRET PER ASME Y14.5M-1994	SCALE: N/A	SHEET 3 OF 3

SIZE:
A3